

# Design To Impress



SPG431

## NEO SERIES

SPG431 reimagines the swing barrier with a slim, refined design that elevates modern commercial and industrial entrances. Built for spaces that demand both performance and prestige, it pairs swift, secure access with a whisper-quiet brushless servo motor, delivering an entrance experience that is as stylish as it is reliable.

## STYLISH SWING BARRIER

### SWING INTO STYLE

The SPG431 is crafted with a silver aluminum alloy body that radiates sophistication. For projects seeking a bolder statement, Red and Violet finishes are available to perfectly complement your building's design.



**Green** light to indicate valid entry.

### GUIDED BY LIGHT

Discreet LED lights provide clear entry signals, guiding every passage with confidence and enhancing security in high-traffic environments.

**Red** light to indicate invalid entry.



**Blue** light to indicate standby.

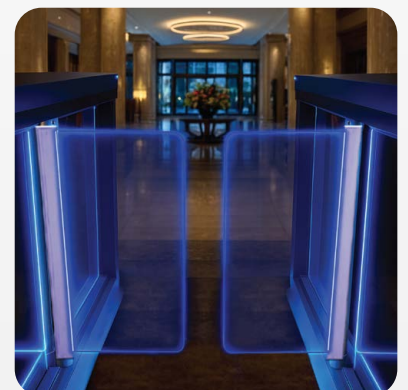

## FEATURE



### Smoother Flow, Lesser Hassle

The SPG431 is built with a dual safety system to protect users and equipment. Six pairs of infrared sensors prevent tailgating and collisions, while the motor's auto-collision reversal minimizes damage in the event of impact. This ensures every passage is safe and secure without compromising smooth access flow.

### Reliable in Emergencies

In emergencies, the gate auto-opens on fire alarm activation or power loss, ensuring a safe and clear evacuation path.

### Maximum Uptime

Full spare parts are readily available to ensure fast replacement, supported by a strong service team to resolve issues in the shortest possible time.

## DIMENSION

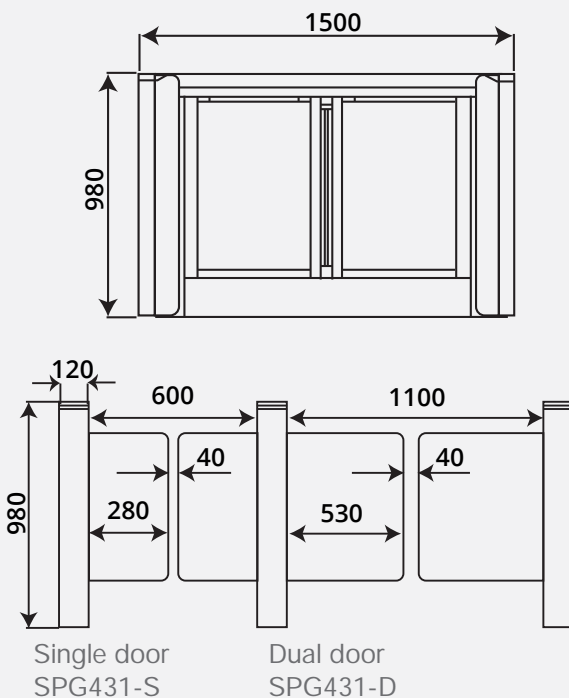

## More Space, Comfortable Access

The SPG431's slim profile allows more lanes to fit within the same space, maximizing throughput in high-traffic areas. With a generous lane width of up to 1.1 meters, it ensures comfortable passage for all users, including those with wheelchairs, prams, or luggage.

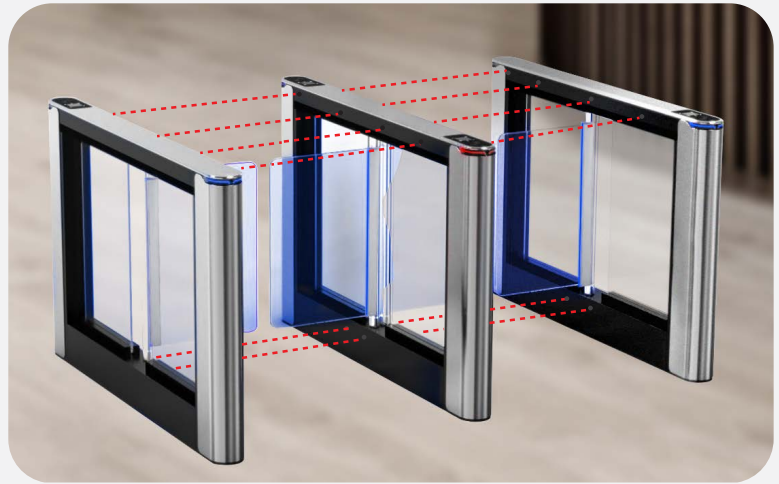

## TECHNICAL SPECIFICATION

Description	Parameters
Body material	Powder coated mild steel (SPCC) Aluminium alloy top and side cover Tempered glass body panel
Passage Width	Standard 600mm, Maximum 1100mm
Door opening / closing speed	Programmable, min 0.5s
Optimal flow rate	Up to 30 people per minute (NC) Up to 50 people per minute (NO)
Power supply	AC110V to 240V, 50/60Hz
Power consumption	<24W (Standby), <150W (Operational)
Motor	DC Brushless Servo Motor, 24V
Input connection	Dry contact
Working environment	Indoor only
Working temperature	-15C - 55C
Relative humidity	<90%, non-condensing
Gate door material	Acrylic, 10.0 + 0.6 mm thick
Cabinet dimension	1500(L) x 120 (W) x 980 (H) mm
MTBF	10 million cycles

## ACCESSORIES



QR Code:  
AR888ULS



Card Access:  
AR721H,  
AR725E



Face Access:  
FR330/FA131  
with mounting  
bracket

### Authorized Dealer:

**ANH PHUONG TECHNOLOGY  
DEVELOPMENT CO., LTD**

Copyright © 2025 Magnet  
Security & Automation Sdn Bhd  
All rights reserved.

All specification, drawing and product info  
are subject to change without prior notice.

